

# BASES TO ISO 5599/1 FOR ISO 5599/1 VALVES SERIES IPV-ISV

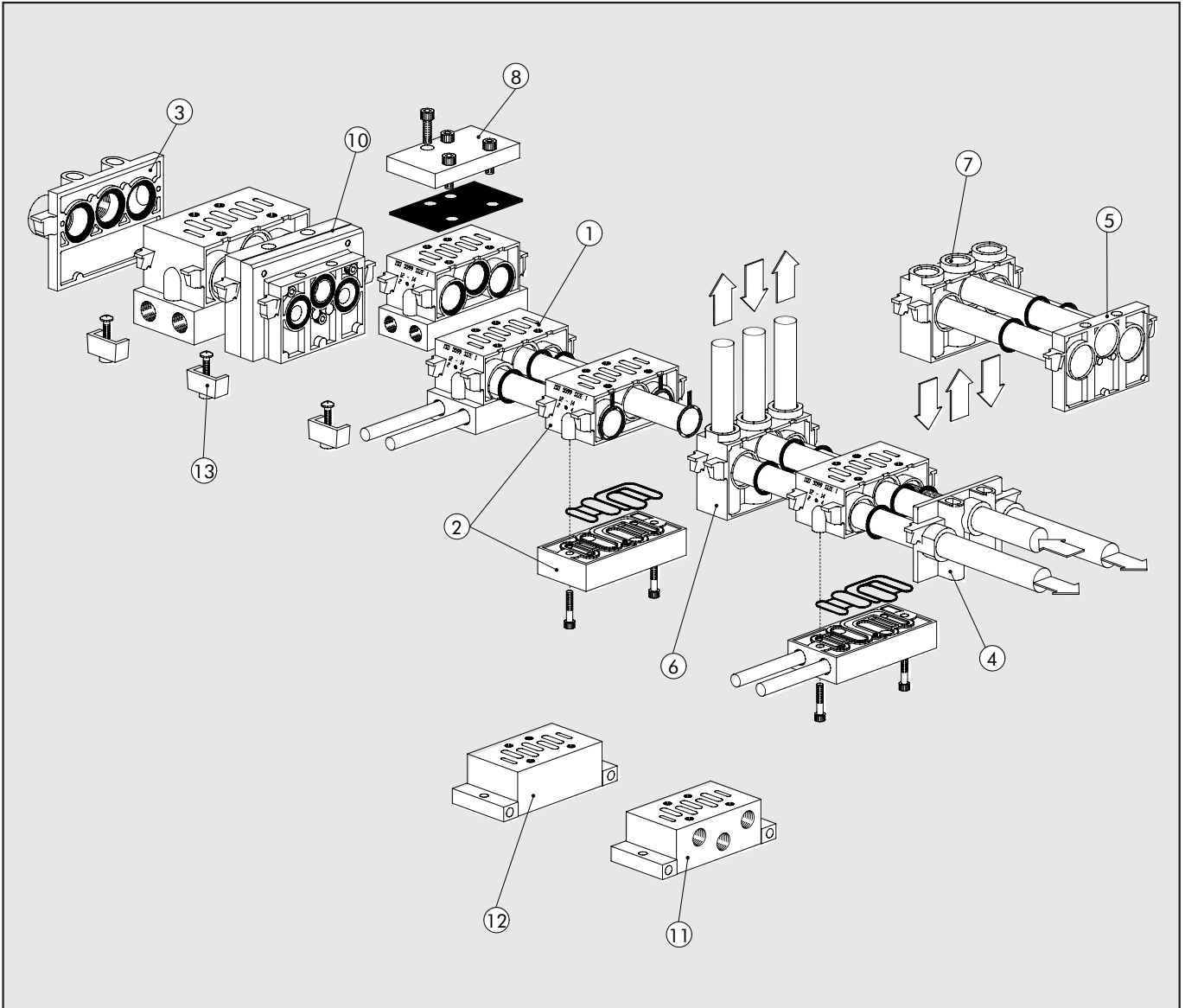

Ref.	Description	ISO 1 Code	ISO 2 Code
①	Manifold base – side ports	0228000150	0228001150
②	Manifold base with bottom ports	0228000155	0228001155
③	Input end plate	0228000200	0228001200
④	Additional input end plate	0228000201	0228001201
⑤	Blind end plate	0228000210	0228001210
⑥	Intermediate – top ports	0228000300	0228001300
⑦	Intermediate – back ports	0228000301	0228001301
⑧	Blanking plate	0228000500	0228001500
⑨	Intermediate diaphragm	0228000400	0228001400
⑩	ISO 1/ISO 2 port adapter	0228000600	-
⑪	Individual base – side ports	0228000100	0228001100
⑫	Base – bottom ports	0228000110	0228001110
⑬	Assembly kit	0228000700	0228001700

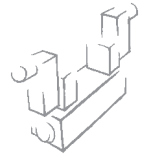

### MANIFOLD BASE, SIDE PORTS, BMS-1

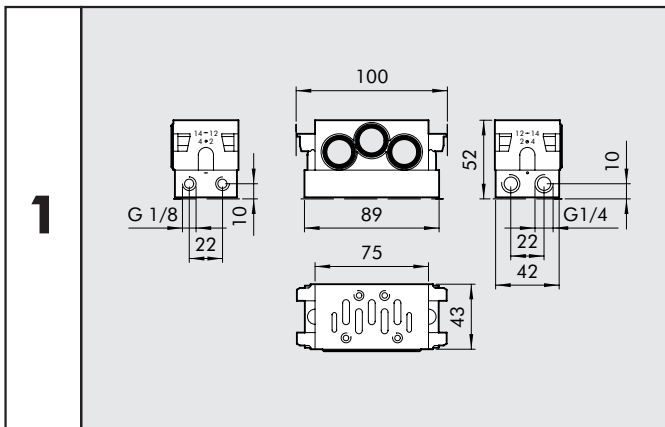

Code	Abbrev.	Weight [g]
0228000150	BMS-1	314

### MANIFOLD BASE, SIDE PORTS, BMS-2

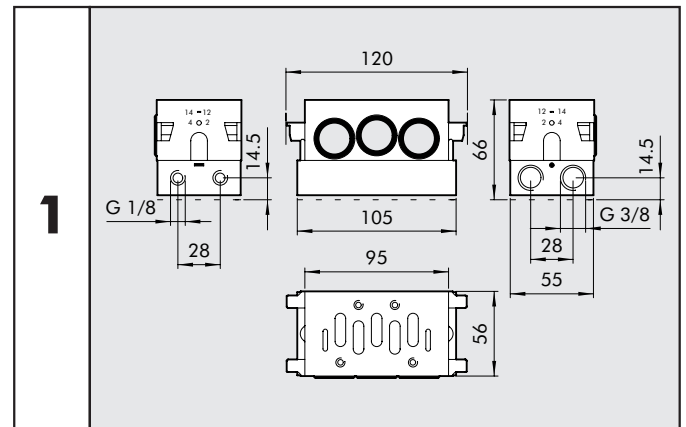

Code	Abbrev.	Weight [g]
0228001150	BMS-2	131

### MANIFOLD BASE, BOTTOM PORTS, BMS-1

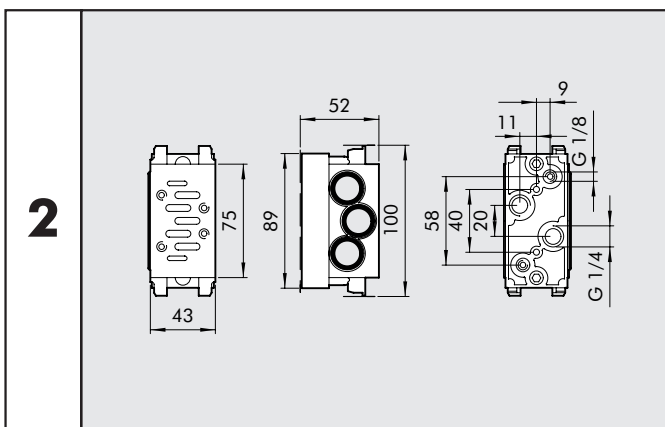

Code	Abbrev.	Weight [g]
0228000155	BMB-1	314

### MANIFOLD BASE, BOTTOM PORTS, BMS-2

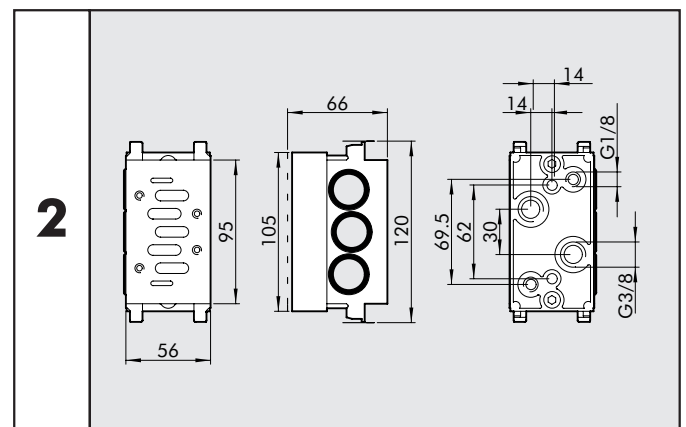

Code	Abbrev.	Weight [g]
0228001155	BMB-2	505

### INPUT END PLATE TIN-1

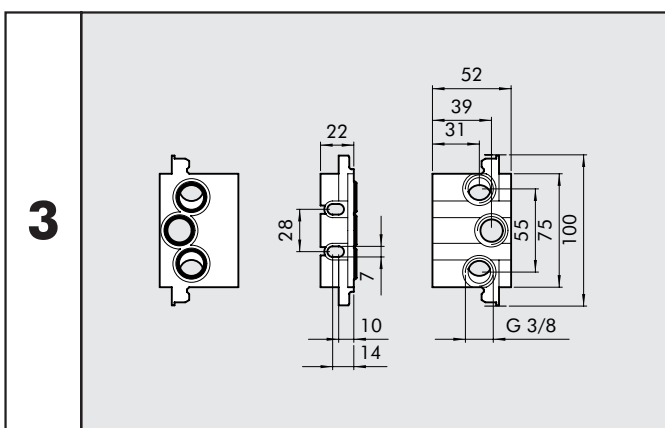

Code	Abbrev.	Weight [g]
0228000200	TIN-1	129

### INPUT END PLATE TIN-2

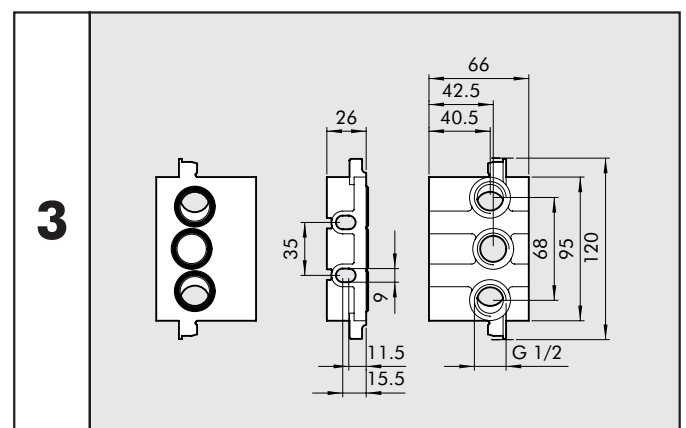

Code	Abbrev.	Weight [g]
0228001200	TIN-2	206

**ADDITIONAL INPUT END PLATE TIS-1**

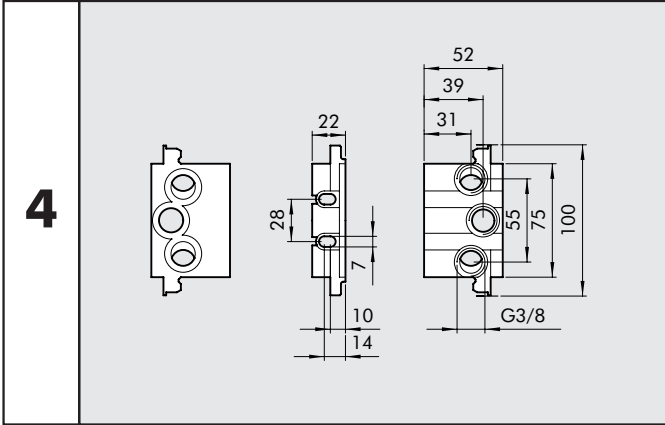

Code	Abbrev.	Weight [g]
0228000201	TIS-1	84

**ADDITIONAL INPUT END PLATE TIS-2**

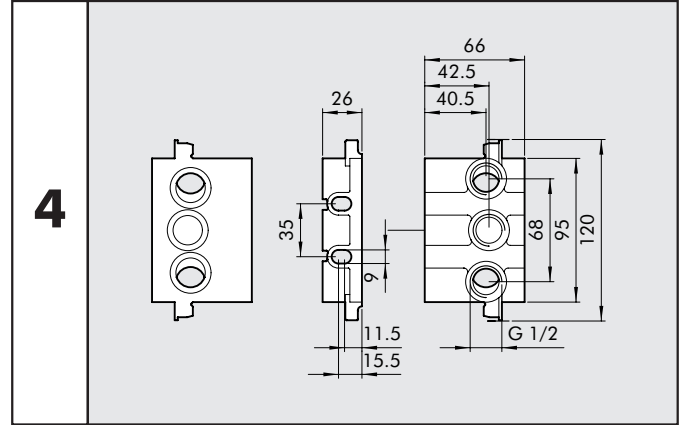

Code	Abbrev.	Weight [g]
0228001201	TIS-2	162

**BLIND END PLATE TCI-1**

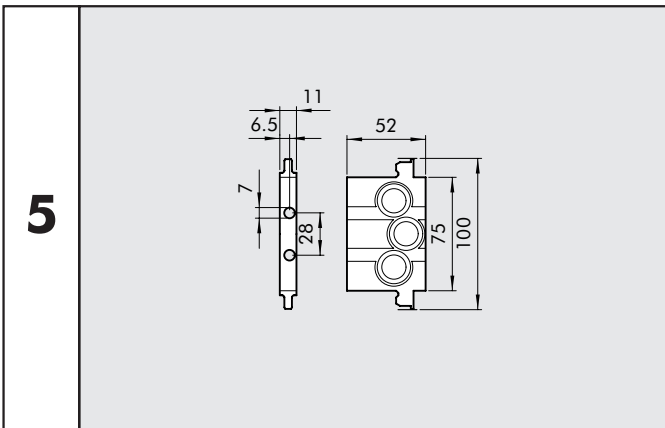

Code	Abbrev.	Weight [g]
0228000210	TCI-1	79

**BLIND END PLATE TCI-2**

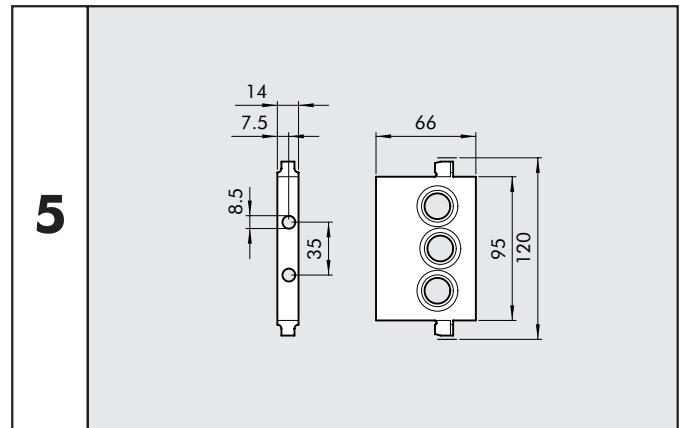

Code	Abbrev.	Weight [g]
0228001210	TCI-2	130

**INTERMEDIATE TOP PORTS TIA-1**

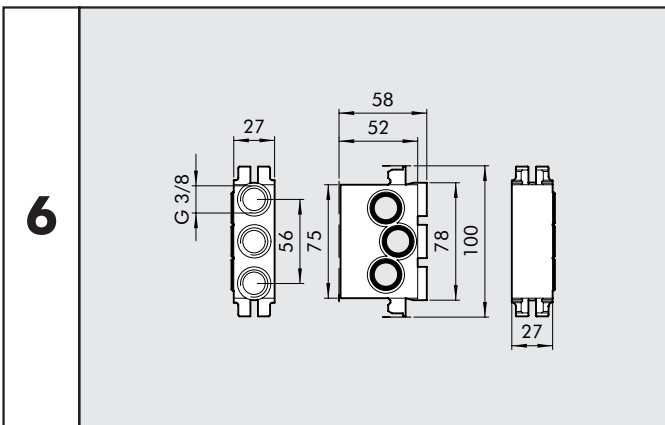

Code	Abbrev.	Weight [g]
0228000300	TIA-1	235

**INTERMEDIATE TOP PORTS TIA-2**

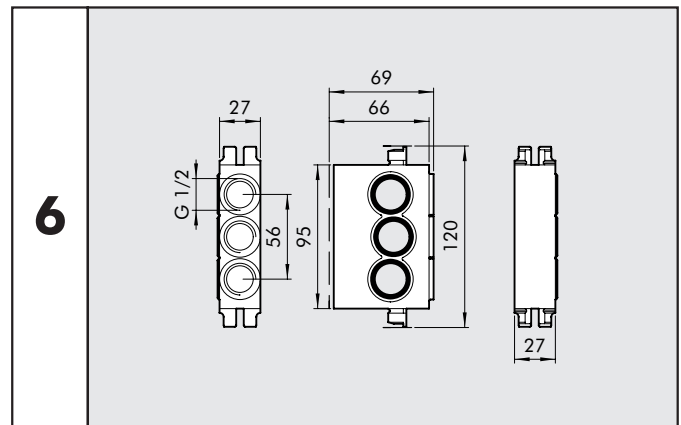

Code	Abbrev.	Weight [g]
0228001300	TIA-2	299

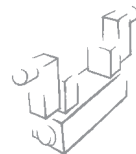

### INTERMEDIATE REAR PORTS TIB-1

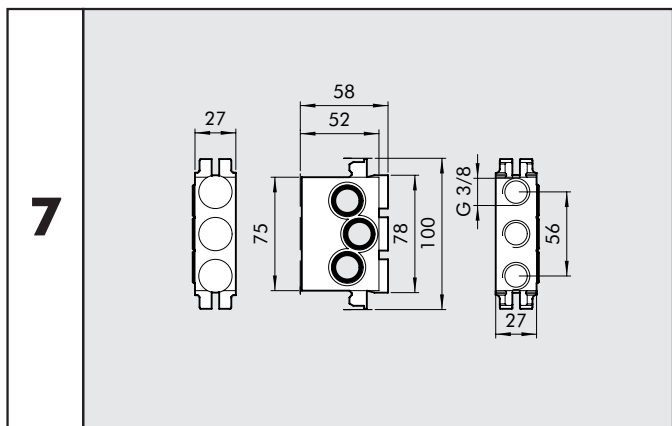

Code	Abbrev.	Weight [g]
0228000301	TIB-1	237

### INTERMEDIATE REAR PORTS TIB-2

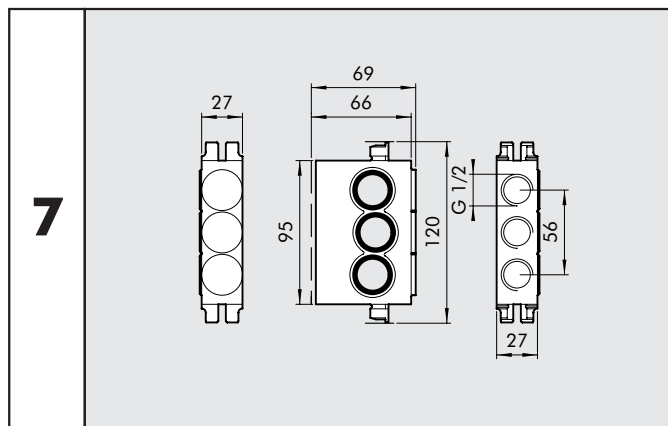

Code	Abbrev.	Weight [g]
0228001301	TIB-2	299

### BLANKING PLATE PCS-1

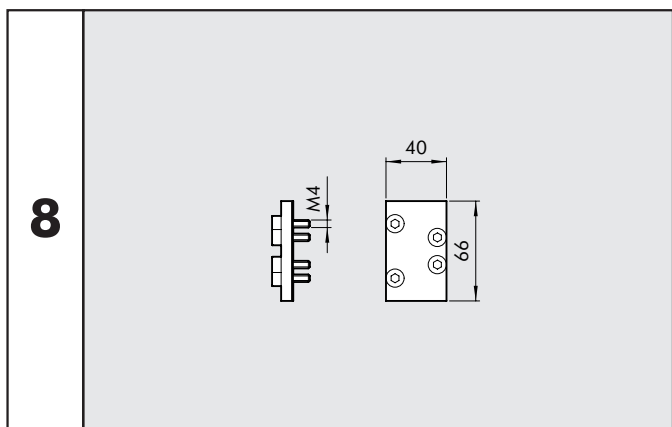

Code	Abbrev.	Weight [g]
0228000500	PCS-1	47

### BLANKING PLATE PCS-2

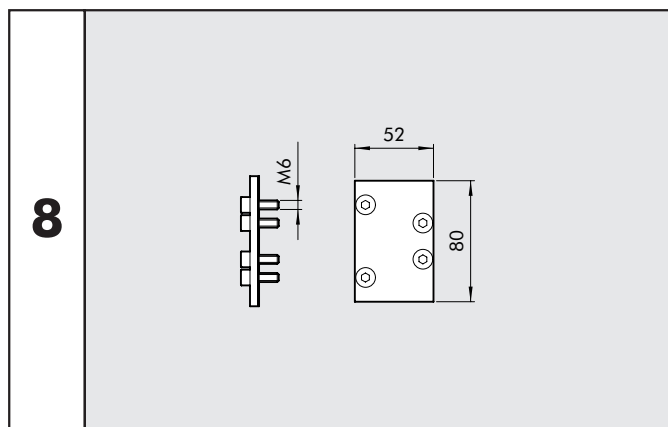

Code	Abbrev.	Weight [g]
0228001500	PCS-2	96

### INTERMEDIATE DIAPHRAGM DIA-1 DIA-2

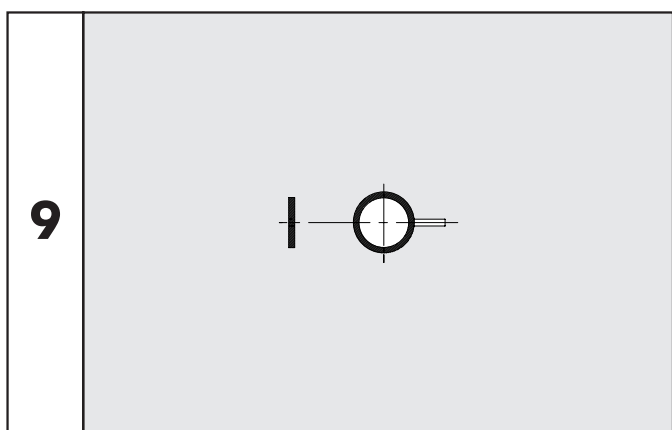

Code	Abbrev.	Weight [g]
0228000400	DIA-1	4
0228001400	DIA-2	7

### DIMENSION ADAPTER ADT 1-2

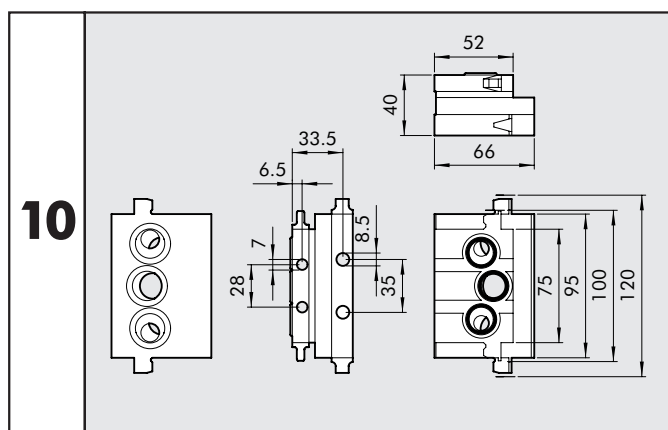

Code	Abbrev.	Weight [g]
0228000600	ADT 1-2	454

**INDIVIDUAL BASE SIDE PORTS BSS-1**

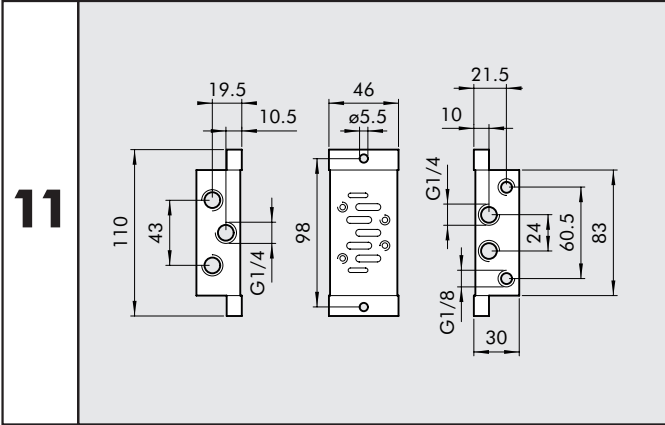

Code	Abbrev.	Weight [g]
0228000100	BSS-1	165

**INDIVIDUAL BASE SIDE PORTS BSS-2**

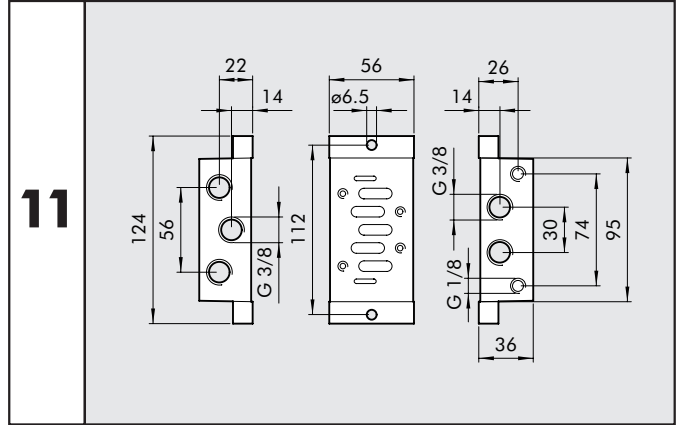

Code	Abbrev.	Weight [g]
0228001100	BSS-2	257

**INDIVIDUAL BASE BOTTOM PORTS BSB-1**

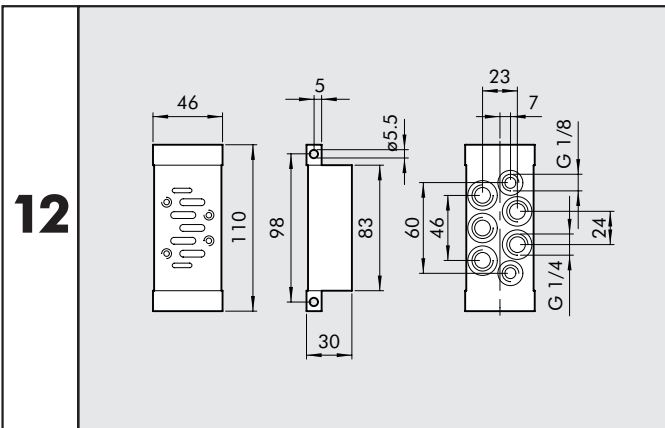

Code	Abbrev.	Weight [g]
0228000110	BSB-1	197

**INDIVIDUAL BASE BOTTOM PORTS BSB-2**

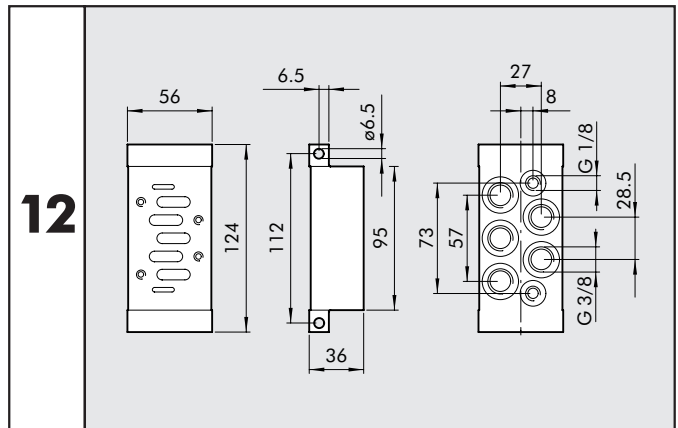

Code	Abbrev.	Weight [g]
0228001110	BSB-2	304

**ASSEMBLY KIT ISO 1**

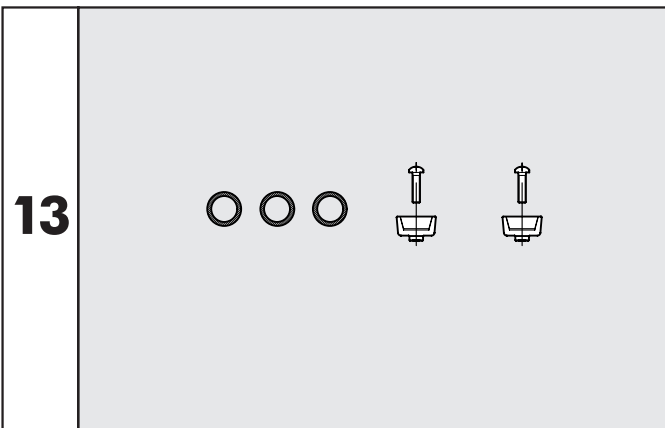

Code	Abbrev.	Weight [g]
0228000700	KIT ISO 1	47

**ASSEMBLY KIT ISO 2**

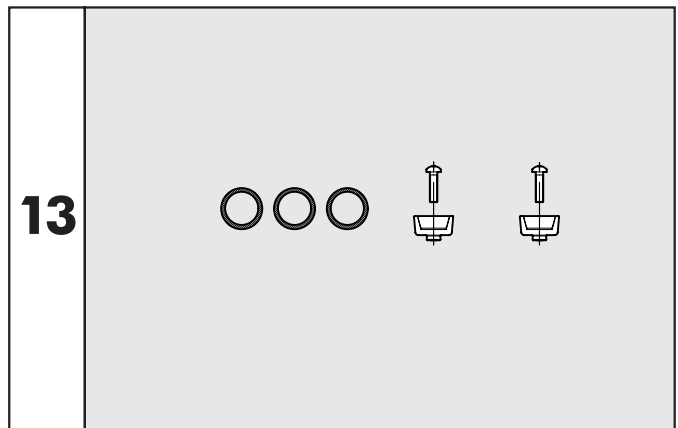

Code	Abbrev.	Weight [g]
0228001700	KIT ISO 2	47